

Highly efficient single-layer dendrimer light-emitting diodes with balanced charge transport

Thomas D. Anthopoulos, Jonathan P. J. Markham, Ebinazar B. Namdas,
and Ifor D. W. Samuel^{a)}

*Organic Semiconductor Center, School of Physics and Astronomy, University of St. Andrews, North Haugh,
St. Andrews, Fife KY16 9SS, United Kingdom*

Shih-Chun Lo and Paul L. Burn^{b)}

The Dyson Perrins Laboratory, Oxford University, South Parks Road, Oxford OX1 3QY, United Kingdom

(Received 31 March 2003; accepted 28 April 2003)

High-efficiency single-layer-solution-processed green light-emitting diodes based on a phosphorescent dendrimer are demonstrated. A peak external quantum efficiency of 10.4% (35 cd/A) was measured for a first generation *fac*-tris(2-phenylpyridine) iridium cored dendrimer when blended with 4,4'-bis(*N*-carbazolyl)biphenyl and electron transporting 1,3,5-tris(2-*N*-phenylbenzimidazolyl)benzene at 8.1 V. A maximum power efficiency of 12.8 lm/W was measured also at 8.1 V and 550 cd/m². These results indicate that, by simple blending of bipolar and electron-transporting molecules, highly efficient light-emitting diodes can be made employing a very simple device structure. © 2003 American Institute of Physics. [DOI: 10.1063/1.1586999]

Over the past ten years, tremendous advances in the area of organic light-emitting diodes (OLEDs) have been achieved mainly through the synthesis of efficient lumophores and the development of improved device structures.^{1–4} Thermally evaporated devices have been demonstrated to be the most efficient with quantum efficiencies approaching 20% and power efficiencies in the region of 60–70 lm/W.^{4,5} These devices implement efficient phosphorescent dopants as the light-emitting medium^{4–7} capable of harvesting light from both singlet and triplet excitons. The best performing phosphorescent dopants have been shown to be those based on iridium (Ir) complexes, which can emit from the metal-ligand charge transfer state.^{4,5,7} These organometallic complexes are highly suitable due to their relatively short excited state lifetime,⁷ high photoluminescence efficiencies, and excellent color tunability.^{8,9} However, in order to achieve the very good performance, complex device structures are required with several charge transport and exciton confinement layers being used.

Solution processible materials such as conjugated polymers^{1,2,10} or dendrimers^{11,12,13} have also demonstrated high efficiency but in much simpler device structures that can be realized by highly cost effective fabrication techniques such as spin coating¹¹ and ink-jet printing.¹⁴ We have recently shown that efficient electrophosphorescence can be obtained from single-layer OLEDs employing a solution processible dendrimer compound doped into a suitable host material.¹¹ We have found that the charge balance can be improved further at some expense of complexity by introducing an electron transporting/hole blocking layer to give a highly efficient bilayer device.¹⁵ Even simpler device structures are desirable and, in this letter, we demonstrate device

efficiency enhancement in a single-layer OLED structure. This is achieved by means of blending the components used in two-layer devices, thereby overcoming the limitations of poor charge injection and balance that are usually encountered in simple single-layer devices, and so giving major improvements in device performance, especially in terms of power efficiency.

The molecular structure of the first-generation *fac*-tris(2-phenylpyridine) iridium cored dendrimer (G1-Ir) and the host materials namely, 4,4'-bis(*N*-carbazolyl)biphenyl (CBP) and 1,3,5-tris(2-*N*-phenylbenzimidazolyl)benzene (TPBI) are shown in Fig. 1. Single-layer devices were formed by spin coating the dendrimer based blends from CHCl₃ solution onto O₂ plasma ashed indium tin oxide (ITO) coated on glass substrates. The cathode contact was then thermally evaporated onto the emissive layer under a vacuum at a base pressure of 7×10^{-7} mbar. A Keithley 2400 source meter and a Keithley 2000 multimeter were used for measuring the current–voltage–light output characteristics of the devices, while for measurement of the electroluminescence (EL) spectra an Instruments SA charge-coupled device spectrograph was employed. Photoluminescence quantum yields (PLQYs) of the films were measured in an integrating sphere¹⁶ utilizing a HeCd laser beam with an excitation wavelength of 325 nm.

The absolute film PLQY were 78% for the 20:80% (G1-Ir:CBP) blend and 64% for the three component 20:52:28% (G1-Ir:CBP:TPBI) blend. The concentration ratios are by weight, and were chosen to optimize device performance (see next). For OLED characterization, two different sets of devices were fabricated employing the single-layer configuration shown in Fig. 1(d). Device structure **1** is comprised of an ITO anode, a 120 nm thick emissive layer (EML) based on the two-component (G1-Ir:CBP) blend, and a cathode electrode. Device structure **2** has the ITO anode, a 120 nm thick EML based on the three-component (G1-Ir:CBP:TPBI) blend, and a cathode electrode. It was established that best

^{a)}Author to whom correspondence should be addressed; electronic mail: idws@st-andrews.ac.uk

^{b)}Author to whom correspondence should be addressed; electronic mail: paul.burn@chem.ox.ac.uk

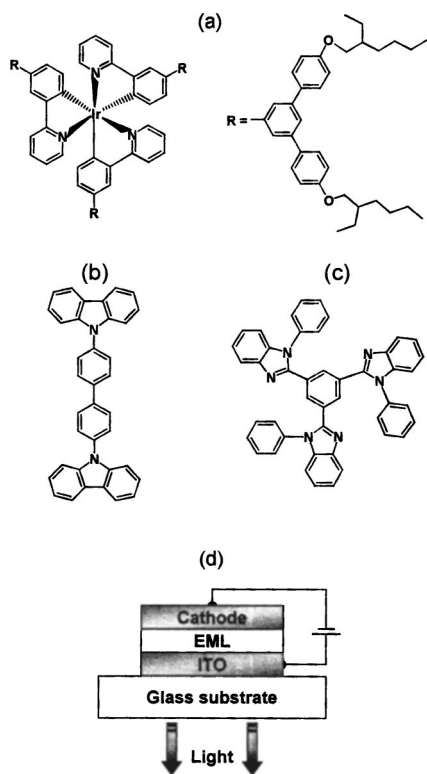

FIG. 1. The molecular structures of: (a) G1-Ir dendrimer, (b) CBP, (c) TPBI, and (d) schematic diagram of the single-layer OLED structure employed.

performance for device structure **1** was obtained with Ca/Al as the cathode, whereas for device structure **2**, LiF/Al was determined to be the best cathode combination. A possible explanation for this observation could be the efficient dissociation of LiF by way of chemical reactions with the three-component organic blend, resulting in enhanced charge transfer across the semiconductor/metal interface as has been previously observed for tris(8-hydroxyquinoline) aluminum (Alq)/LiF/Al interfaces.¹⁷ However, the reaction pathways between LiF and G1-Ir:CBP:TPBI blends are not yet clear and further work is needed in order to elucidate the exact mechanism.

In both device structures, EL emission is found to originate only from the dendrimer with a peak at 518 nm and a vibronic shoulder at 545 nm. This characteristic is similar to that reported previously for evaporated *fac*-tris(2-phenylpyridine) iridium [Ir(ppy)₃]-based OLEDs.⁷ It is important to note that no host emission is visible from either of the two blends implying a complete energy or charge transfer from the other components of the blend to the dendrimer. Figure 2(a) shows the external quantum efficiency (EQE) as a function of bias voltage for device structures **1** and **2**. As can be seen, the EQE for device structure **2** exhibits higher values throughout the entire voltage range investigated, with a maximum value of 10.4% measured at 8.1 V. The difference in efficiency is particularly marked at lower voltages. For example at 6 V, device structure **2** exhibits an EQE of 7.4% compared with 0.21% for device structure **1**. This is a significant improvement since low-voltage operation was previously an issue for single-layer dendrimer-based OLEDs.^{11–13,18}

We now consider the reasons for the improvement. In order to further investigate the transport process in these de-

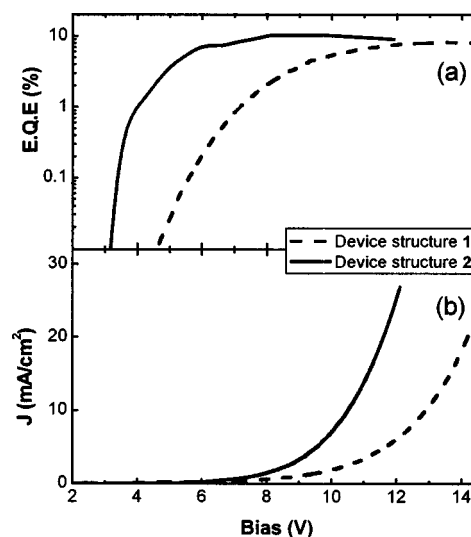

FIG. 2. (a) EQE (%) of device structure **1** (G1-Ir:CBP, dashed line) and device structure **2** (G1-Ir:CBP:TPBI, solid line) as a function of bias voltage (V). (b) Current density (J) vs voltage (V) characteristics obtained for the two devices.

vices, the forward bias characteristics are plotted in Fig. 2(b). It can be seen in Fig. 2(b) that the current density is larger for device structure **2** throughout the measurement range. This current enhancement mechanism can be better understood on the basis of the device energy level diagram shown in Fig. 3. TPBI is hole blocking in character [highest occupied molecular orbital (HOMO) at 6.7 eV] so the hole current through device structure **2** will be lower than for device structure **1**. The higher current observed must, therefore, be due to an increased electron current. TPBI favors this in two ways. The first is that the energy of its lowest unoccupied molecular orbital (LUMO) reduces the barrier to electron injection. The second is that the electron transporting character of TPBI may increase the electron mobility in device structure **2**. By improving charge injection and transport in this way, a shift of the recombination zone further away from the cathode is expected, reducing any cathode induced EL quenching. It is found that the carrier injection/transport

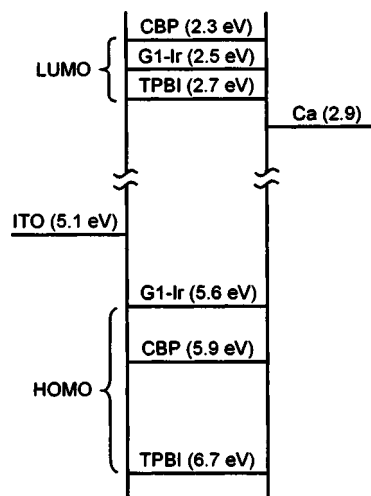

FIG. 3. Energy level band diagram for the constituent materials employed in the present study. HOMO and LUMO are the highest occupied and lowest unoccupied molecular orbitals, respectively (energy levels taken from Ref. 15).

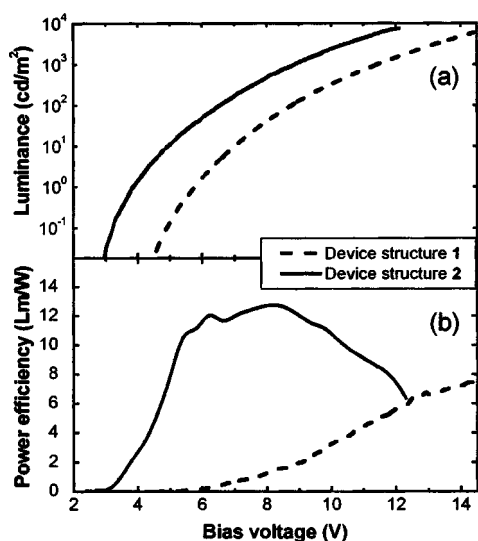

FIG. 4. The characteristics of: (a) Luminance vs voltage (cd/m^2 vs V) and (b) power efficiency vs voltage (lm/W vs V) of the G1-Ir dendrimer-based device structure 1 and 2 OLEDs, respectively.

properties of device structure 2 change as the composition of its active layer is adjusted in order to achieve the best efficiency. In the present work, the optimum G1-Ir:CBP:TPBI ratio was found to be 20:52:28 wt %, respectively. When the concentration of TPBI was further reduced or increased a gradual drop in the EQE of the devices was observed. In Fig. 4(a), the light output (cd/m^2), for both devices, is plotted against the bias voltage. It is evident that device structure 2 exhibits a much lower turn-on voltage for light emission (2.9 V) than device structure 1 (4.4 V). The operating voltage for device structure 2 at 100 cd/m^2 is 6.6 V; a much lower value compared with that measured for device structure 1 (8.8 V). Further conclusive evidence on the improving effect of having TPBI in the blend are provided in Fig. 4(b) where the power efficiency (lm/W) for both devices is plotted as a function of bias voltage. A significant enhancement for device structure 2 is observed with a maximum power efficiency of 12.8 lm/W reached at 8.1 V (550 cd/m^2) and a corresponding EQE of 10.4%. Such a high performance, for a single-layer OLED, approaches the values of 12%–20% reported so far in literature for evaporated devices.^{4,5,19–21} Furthermore, it demonstrates how charge carrier balance within a high photoluminescence efficiency blend, coupled with the superior film forming properties of dendrimers, can lead to highly efficient and easy-to-fabricate light-emitting devices.

In summary, the effects of blending charge-transporting

molecules, with phosphorescent iridium-based dendrimer, on the performance characteristics of single-layer OLEDs have been investigated. Results indicate that the addition of electron-transporting TPBI into a blend of G1-Ir:CBP gives a significant improvement in device efficiency and reduces the operating voltage. The improved performance is assigned to enhanced electron injection from the LiF/Al cathode and transport through the EML due to the presence of TPBI. We believe that this simple approach will lead to further improvements in single-layer OLEDs performance.

The authors are grateful to CDT Oxford Ltd., EPSRC, and SHEFC for financial support. One of the authors (I.D.W.S.) is a Royal Society Research Fellow.

- ¹R. H. Friend, R. W. Gymer, A. B. Holmes, J. H. Burroughes, R. N. Marks, C. Taliani, D. D. C. Bradley, D. A. Dos Santos, J. L. Bredas, M. Logdlund, and W. R. Salaneck, *Nature (London)* **397**, 121 (1999).
- ²P. K. H. Ho, J. S. Kim, J. H. Burroughes, H. Becker, S. F. Y. Li, T. M. Brown, F. Cacialli, and R. H. Friend, *Nature (London)* **404**, 481 (2000).
- ³C. W. Tang, *Inf. Disp.* **12**, 16 (1996).
- ⁴C. Adachi, M. A. Baldo, M. E. Thompson, and S. R. Forrest, *J. Appl. Phys.* **90**, 5048 (2001).
- ⁵M. Ikai, S. Tokito, Y. Sakamoto, T. Suzuki, and Y. Taga, *Appl. Phys. Lett.* **79**, 156 (2001).
- ⁶M. A. Baldo, D. F. O'Brien, Y. You, A. Shoustikov, S. Sibley, M. E. Thompson, and S. R. Forrest, *Nature (London)* **395**, 151 (1998).
- ⁷M. A. Baldo, M. E. Thompson, and S. R. Forrest, *Nature (London)* **403**, 750 (2001).
- ⁸C. Adachi, M. A. Baldo, S. R. Forrest, S. Lamansky, M. E. Thompson, and R. C. Kwong, *Appl. Phys. Lett.* **78**, 1622 (2001).
- ⁹C. Adachi, R. C. Kwong, P. Djurovich, V. Adamovich, M. A. Baldo, M. E. Thompson, and S. R. Forrest, *Appl. Phys. Lett.* **79**, 2082 (2001).
- ¹⁰I. S. Millard, *Synth. Met.* **111**, 119 (2000).
- ¹¹J. P. J. Markham, S. -C. Lo, S. W. Magennis, P. L. Burn, and I. D. W. Samuel, *Appl. Phys. Lett.* **80**, 2645 (2002).
- ¹²J. M. Lupton, I. D. W. Samuel, R. Beavington, P. L. Burn, and H. Bassler, *Adv. Mater. (Weinheim, Ger.)* **13**, 258 (2001).
- ¹³M. Halim, J. N. G. Pillow, I. D. W. Samuel, and P. L. Burn, *Adv. Mater. (Weinheim, Ger.)* **11**, 371 (1999).
- ¹⁴T. R. Hebner, C. C. Wu, D. Marcy, M. H. Lu, and J. C. Sturm, *Appl. Phys. Lett.* **72**, 519 (1998).
- ¹⁵S.-C. Lo, N. A. Male, J. P. J. Markham, S. W. Magennis, P. L. Burn, O. V. Salata, and I. D. W. Samuel, *Adv. Mater. (Weinheim, Ger.)* **14**, 975 (2002).
- ¹⁶N. C. Greenham, I. D. W. Samuel, G. R. Hayes, R. T. Phillips, Y. A. R. R. Kessener, S. C. Moratti, A. B. Holmes, and R. H. Friend, *Chem. Phys. Lett.* **241**, 89 (1995).
- ¹⁷D. Grozea, A. Turak, X. D. Feng, Z. H. Lu, D. Johnson, and R. Wood, *Appl. Phys. Lett.* **81**, 3173 (2002).
- ¹⁸W. Freeman, S. C. Koene, P. R. L. Malenfant, M. E. Thompson, and J. M. J. Frechet, *J. Am. Chem. Soc.* **122**, 12385 (2000).
- ¹⁹C. Adachi, R. Kwong, and S. R. Forrest, *Organ. Electron.* **2**, 37 (2001).
- ²⁰B. W. D'Andrade, M. A. Baldo, C. Adachi, J. Brooks, M. E. Thompson, and S. R. Forrest, *Appl. Phys. Lett.* **79**, 1045 (2001).
- ²¹G. E. Jabbour, J.-F. Wang, and N. Peyghambarian, *Appl. Phys. Lett.* **80**, 2026 (2002).