

# Contrast, stimulus selectivity and neuronal responses

Mike Oram

Institute of Adaptive & Neural Coding  
Edinburgh  
&  
School of Psychology  
St Andrews

## Example stimuli

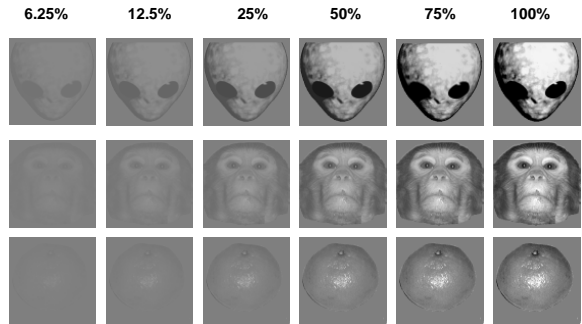

## Latency increases as contrast decreases

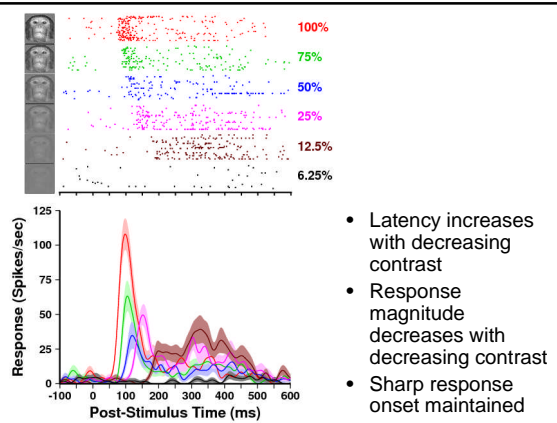
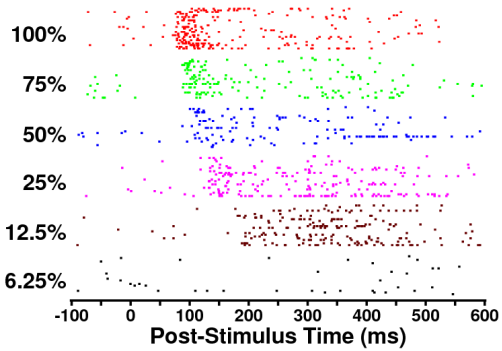

## Average cell

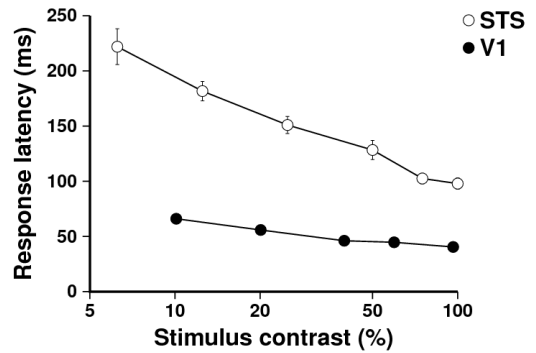
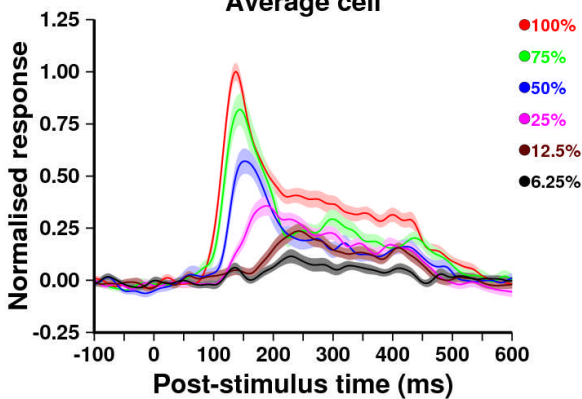

Stimulus contrast influences response latency more in late visual areas (STS) than in early areas (V1)

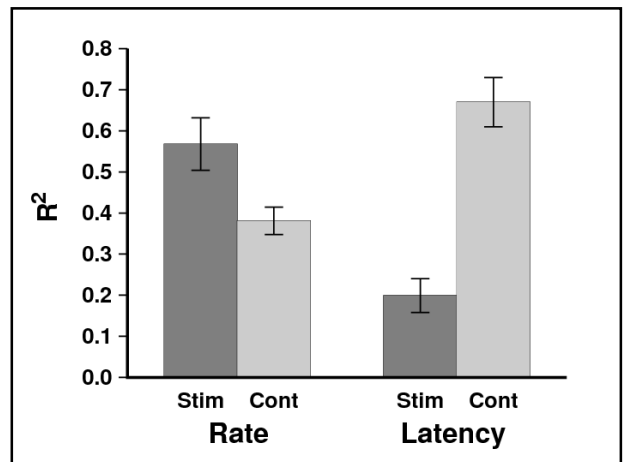
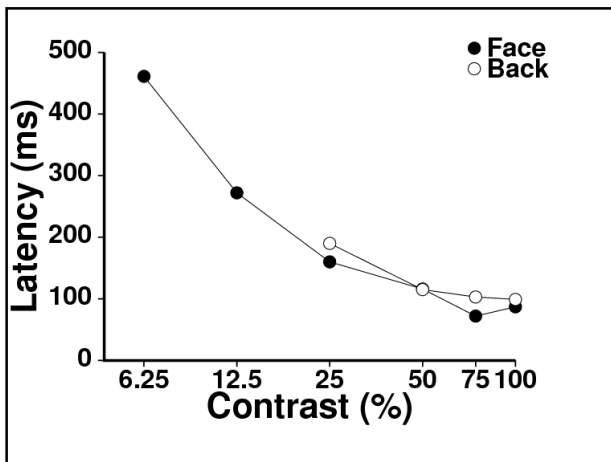
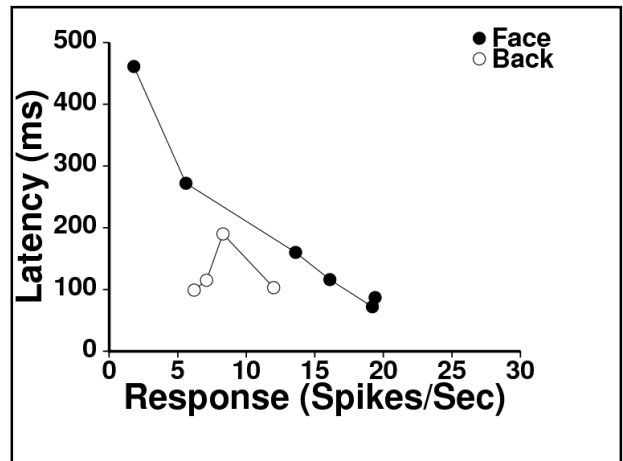
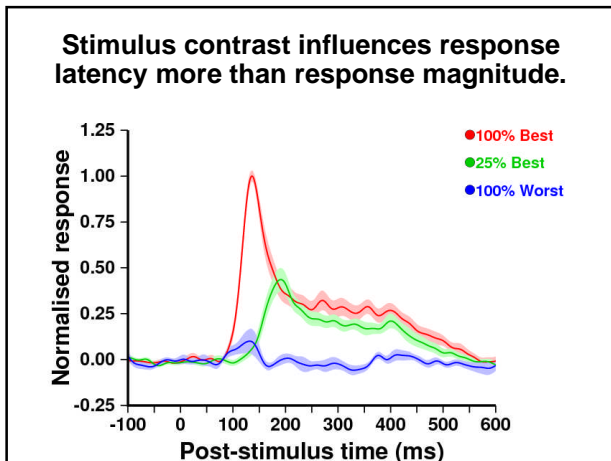

**Contrast, latency & STS**

- Large effect of contrast on response latency
  - Larger in STS than V1
- Large effect of stimulus on response magnitude
- Starting to model large (>300ms) latency changes

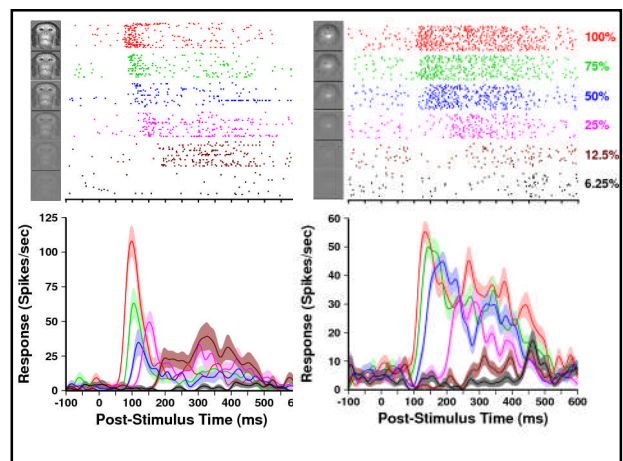

## Recurrent network & depressing synapses



- Low signal:noise
  - Long latency, fast rise with
- High signal:noise
  - Short latency, fast rise with
- with Mark van Rossum

## Contrast dependent latency

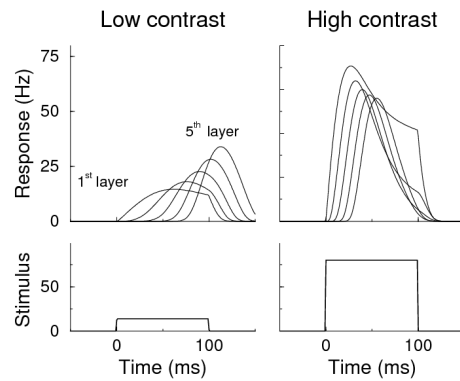

## Population network

(recurrent not shown)

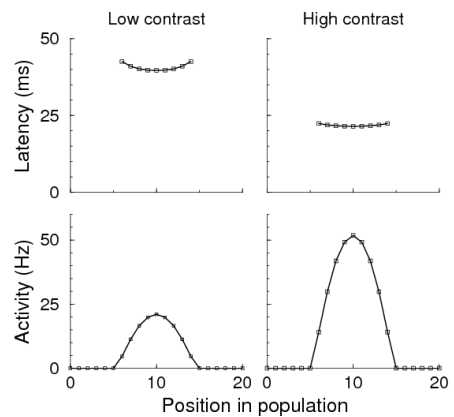
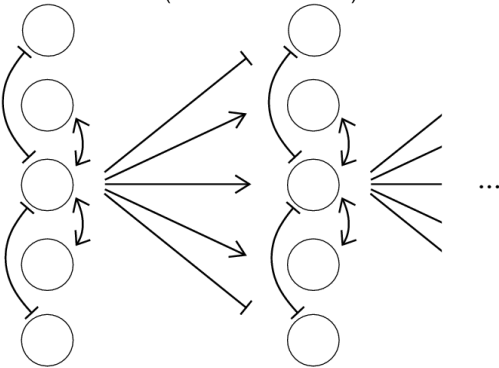

## Interim summary

- Model with depressing synapses
  - Firing rate varies with stimulus
  - Response latency varies with contrast
  - Can give rise to large latency changes
    - Other models (e.g. Carandini & Heeger 1994) don't
  - Give sharp response onset
    - Threshold models (e.g. Bugmann 1992) don't
- Do other factors influence latency?

## High specificity



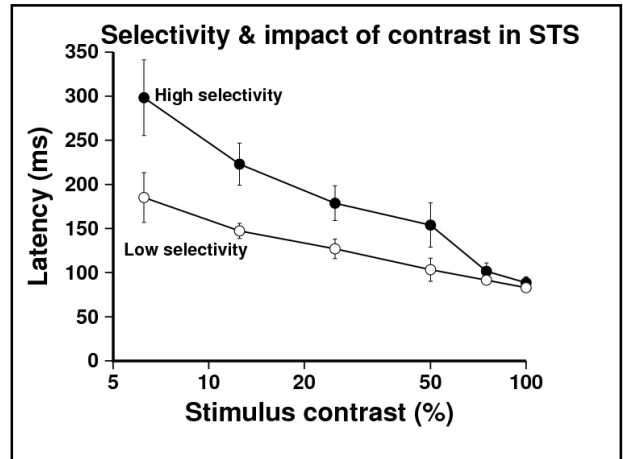
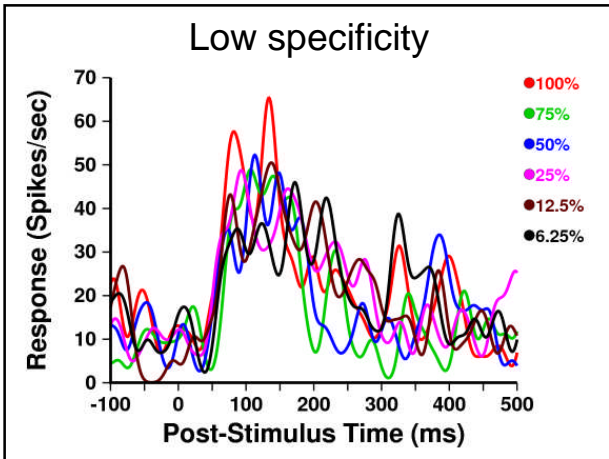
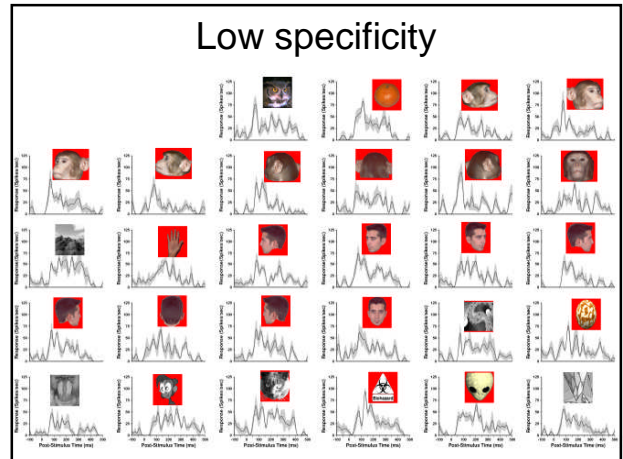
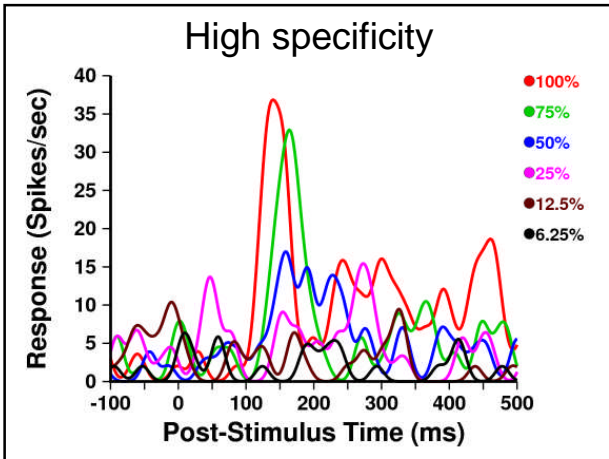

### Why selectivity?

- High selectivity maybe related to "complexity" of computations
  - Finesse the details of "complexity"
  - Start with linear vs non-linear

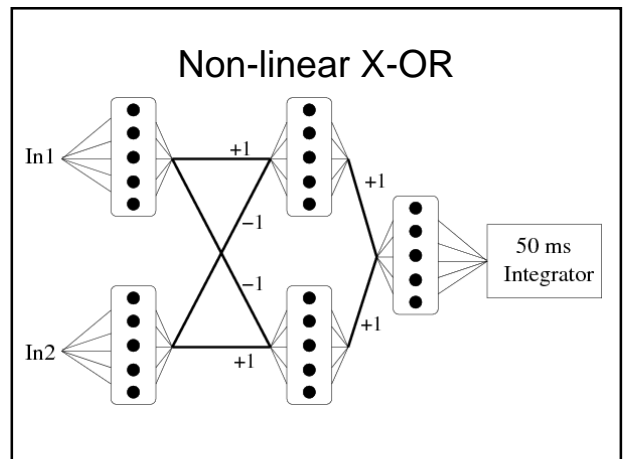

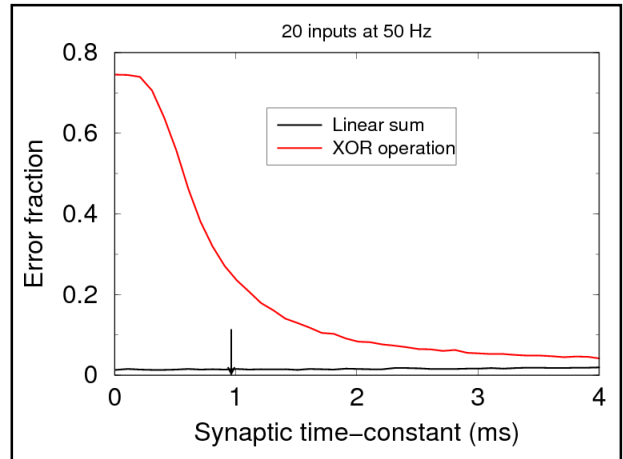
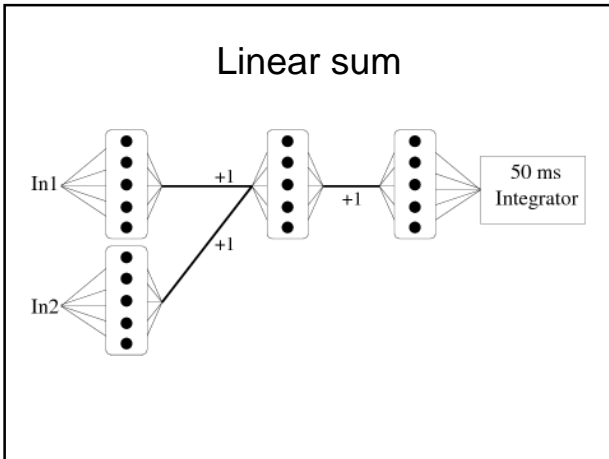

- ### Integration & linearity
- Linear operations (sum)
    - Can integrate at end of calculations
      - Noise / errors averaged out
  - Non-linear operations (X-OR)
    - Integration at end does not average out errors
      - GIGO principle
    - Need to increase integration time (synaptic time constant) throughout system

- ### Summary
- Adaptive network time constant
    - At low contrast
      - Increased latency
        - Independent of response magnitude (Gawne et al 1996)
      - Predict increased influence of lateral connectivity
        - Space in V1 (Sceniak et al 1999)
        - Perhaps stimulus similarity (space) in IT/STS?
    - Adaptation varies with computation
      - Linear: temporal integration at any stage
      - Non-linear: require integration at each stage
      - Dependence of contrast ~ latency function on response selectivity

- ### Summary
- Need more data
    - No longer possible at St Andrews
    - Anyone interested?
    - Know of someone who might be interested?

